



## Aussie Cobra Series Drain Cleaning Jetters

September 2012

# Operator's Instruction Manual



Operators must read this manual and understand it before operating this machine

Ref: ACOBRAMANVER1

# Aussie Pumps

## AUSSIE DRAIN CLEANING JETTER RISK ASSESSMENT

### MODELS:

In line with the National Occupation Health & Safety Commission's requirements the data below applies to the Aussie Cobra series of drain cleaning models:

- Aussie Mini Cobra
- Aussie Cobra
- Aussie King Cobra
- Aussie Python (pump motor group)

### DESCRIPTION:

Engine drive high pressure drain cleaning jetters designed for both domestic and professional cleaning applications.

### MATERIAL CONSTRUCTION:

Aussie drain cleaning jetters are mounted on heavy duty steel skids or trolley mounted frames. They consist of a quality internal combustion petrol or diesel engine driving a triplex style three piston high pressure pump. The machines are supplied with wheels (except for Aussie Pythons) for ease of portability and manoeuvrability. The machines can be supplied with hose reels and up to 60 metres of sewer hose to increase operator convenience.

### RISK RANKING METHOD:

Risk is the combination of the likelihood of a specific unwanted event and the potential consequences if it should occur.

#### PROBABILITIES:

- A. Common or repeating occurrence.
- B. Known to occur or "it has happened".
- C. Could occur, or "I've heard of it happening".
- D. Not likely to occur.
- E. Practically impossible.

#### CONSEQUENCES FOR PEOPLE:

- 1. Fatality or permanent disability.
- 2. Serious lost time, injury or illness.
- 3. Moderate lost time, injury or illness.
- 4. Minor lost time, injury or illness.
- 5. No lost time.

### RISK RANKING METHOD:

For each event, the appropriate probability (a letter A to E) and consequences (a number 1 to 5) is selected.

### RISK RANKING TABLE:

The consequences (loss outcomes) are combined with the probability (of those outcomes) in the risk ranking table to identify the risk rank of each loss event (e.g. a consequence of 3 with a probability of B yields a risk rank of 9).

The table yields a risk rank from 1 to 25 for each set of probabilities and consequences. A rank of 1 is the highest magnitude or risk that is a highly likely, very serious event. A rank of 25 represents the lowest magnitude of risk, an almost impossible very low consequence event.

Controls must be taken to either eliminate or minimise the risk.

		PROBABILITY				
		A	B	C	D	E
C O N S E Q U E N C E	1	1	2	4	7	11
	2	3	5	8	12	16
	3	6	9	13	17	20
	4	10	14	18	21	23
	5	15	19	22	24	25

**PLAN SAFE .... STAY SAFE**

POTENTIAL HAZARD:

Hazard	Yes/No	Risk	Risk Rating	Controls
Entanglement with sewer hose (tripping, falling)	Yes	Personal injury of the operator or bystanders	13	<ul style="list-style-type: none"> <li>Warning stickers</li> <li>hose reel option</li> </ul>
Injury from high pressure water	Yes	Personal injury of the operator or bystanders	13	<ul style="list-style-type: none"> <li>Warning notice on jetter</li> <li>Warning in Operator's Manual,</li> <li>Use of safety protection clothing (Aussie Pro-operator)</li> <li>Use of barriers to keep bystanders away from work area</li> </ul>
Injury from whipping hose if jetter run with hose out of drain	Yes	Personal injury of the operator or bystanders	13	<ul style="list-style-type: none"> <li>Warning in operator's manual</li> <li>Warning sticker on jetter</li> </ul>
Suffocation	Yes	Fatality is the risk	7	<ul style="list-style-type: none"> <li>Machine decal warning about operation in confined spaces</li> <li>Operator training in working in confined spaces</li> </ul>
Ergonomic lifting or movement on site, including drain covers	Yes	Personal injury	8	<ul style="list-style-type: none"> <li>Machine decal warning about correct lifting procedures</li> <li>Operator's Manual</li> <li>Staff training</li> <li>Long handled drain cover keys</li> </ul>
High temperature (from engine muffler and other components)	Yes	Burns from muffler	15	<ul style="list-style-type: none"> <li>Warning sticker on machine</li> </ul>
Fire or explosion caused by refuelling engine while running	Yes	Serious injury, burns	8	<ul style="list-style-type: none"> <li>Warning sticker on machine</li> </ul>
Unsecured machine, moves unattended	Yes	Cause of accidents and/or injury	18	<ul style="list-style-type: none"> <li>Warning sticker "Secure Machine during Operation"</li> <li>Operator's Manual</li> </ul>
Noise	Yes	Hearing damage	15	<ul style="list-style-type: none"> <li>Warning sticker regarding ear muffs to be used during operation</li> </ul>
Dislodged particles in atmosphere	Yes	Sight damage	6	<ul style="list-style-type: none"> <li>Warning regarding wearing safety glasses.</li> </ul>
Slipping on wet surface	Yes	Personal injury	9	<ul style="list-style-type: none"> <li>Use of proper footwear</li> </ul>
Contact with foul water or sewage	Yes	Infection, illness from water splashes, ingested water	9	<ul style="list-style-type: none"> <li>Personal protective equipment, ie gloves, overalls, boots, eye and/or face protection etc</li> <li>Operator to use good basic hygiene</li> </ul>
Contact with chemical cleaners used to clean drains	Yes	Skin contact could result in burns, skin irritation etc. Fumes from some chemicals may lead to respiratory problems	4	<ul style="list-style-type: none"> <li>Chemical cleaners to only be used as a last resort when other methods have failed.</li> <li>Areas to be kept well ventilated.</li> <li>Staff to follow manufacturers' instructions at all time for use, storage &amp; disposal.</li> <li>Staff to wear the appropriate PPE</li> <li>Respiratory protection when required</li> </ul>

Signed originator .....

Job title.....

Date Completed .....

Aussie Pro-Operator gear ...  
 Good to 500 BAR (7,300 PSI)  
**THE PROTECTION YOU NEED!**



## Contents

AUSSIE DRAIN CLEANING JETTER RISK ASSESSMENT .....	2
Warranty Coverage .....	4
STAY SAFE .....	5
Safety Clothing .....	5
Engine Hazards .....	5
Jetter Warning .....	5
Wash Down Operation .....	5
Bacteria Warning .....	5
SAFETY PRECAUTIONS .....	6
Work Area Safety ... minimise hazards .....	6
Specifications .....	7
Accessory Identification .....	7
Assembly & Preparation for Use .....	8
Start Up & Operation .....	8
Operation as a Drain Cleaning Jetter .....	9
Operation as a High Pressure Washer .....	9
ASP System ... Aussie Safety Protection System .....	10
High Pressure Piston Pumps & Plumbing .....	10
Personal Protective Equipment ... STAY SAFE .....	11
Operating Tips .....	12
Nozzle Selection .....	13
Operator's Hand Signals .....	14
Accident Reporting .....	14
Emergency Medical Information .....	15
Service Record .....	15
Maintenance, Service and Spares .....	16
Troubleshooting Guide .....	16
Pump Kits .....	17
Replacement Parts .....	19
Warnings .....	20
Pressure Cleaner Daily Check List .....	20
Three Monthly Regular Service .....	20

## Thank you for purchasing an Aussie Cobra Drain Cleaning Jetter



We want you to get the best results from your new machine and operate it safely. This manual contains information on how to do that, please read it carefully before operating the machine.

### CAUTION

Please note that drain and sewer cleaning procedures must be followed carefully. If not it can result in severe injury or even death. Appropriate safety clothing and equipment must be used at all times.

The Aussie Cobra series of drain cleaning jetters use water at high pressure to clear blockages such as grease, sediment and tree roots from drains. The pressure is generated by restricting the flow of water with a nozzle at the end of an extremely flexible sewer hose.

The nozzle has reverse facing jets that cause the water to propel the hose along the drain clearing blockages and flushing away the debris.

## Warranty Coverage



Aussie Pumps is proud to use engines from the world's best engine manufacturers. These engines carry a full international warranty provided by these manufacturers and is backed up by their extensive dealer network.

Please refer to the engine manual for the full terms and conditions of the engine warranty and your responsibilities of ownership. If a problem should arise or if you have any questions about your engine, consult an authorised service agent. Check online for your nearest engine dealer.



The **Bertolini pump** fitted to the drain cleaning jetter has a **three year warranty**, providing it is serviced by an authorised service agent every six months. Keep your receipt as proof of purchase and all service receipts to maintain this warranty. This guarantee is invalid if the product is found to have been abused in any way, or not used for the purpose for which it was intended.

The battery fitted to your jetter is an Absorbed Glass Mat dry cell battery with a full one year warranty from the battery manufacturer. For service contact your DEKA Battery agent via Ryde Federal Batteries (02) 9879 5422. Please read the safety information regarding the battery to prevent possible injuries.

Routine maintenance is the owner's responsibility. Failure to maintain the machine in line with the services outlined on the back page will invalidate warranty. High pressure accessories carry a 3 month warranty.

The Aussie Drain Cleaning Jetter has a two year warranty from date of purchase. This warranty covers any defect which occurs due to faulty workmanship or material under normal use. This warranty specifically excludes the following:

- Damage resulting from debris or mineral deposits contained within the water supply to the machine.

- Leaking hoses when the outer cover of the hose has been abraded or the hose has been kinked.
- Damage to o-rings and valves, etc. caused by the use of cleaning chemicals or compounds.
- Replacement of parts damaged due to fair wear and tear.
- Misuse, negligence, alteration, accident or breakage.
- Failure of the machine due to lack of normal maintenance services (The owner is responsible for the performance of regular maintenance services, as specified in the Operator's Manual).
- Damage and/or progressive damage caused by the failure to inform Australian Pump Industries Pty Ltd, or the closest Authorised Australian Pump Agent or Distributor, within seven days of the defect becoming apparent.
- Repair or modification by an unauthorised service person.

Australian Pump Industries Pty Ltd specifically excludes from warranty responsibility any consequential loss or damage including on-site servicing, loss of time, loss of use of the machine, hire costs of a replacement machine or inconvenience.

Where possible return faulty goods to the place of purchase. No products can be returned to us without prior permission. The reason for return must be clearly stated.

N.B. Warranty is not transferable to third parties in the event of sale of the machine within the warranty period. Please note that any parts used in warranty repairs are guaranteed for a period limited by the original warranty of the parent product.

Our goods come with guarantees that cannot be excluded under the Australian Consumer Law. You are entitled to a replacement or refund for a major failure and for compensation for any other reasonably foreseeable loss or damage. You are also entitled to have the goods repaired or replaced if the goods fail to be of acceptable quality and the failure does not amount to a major failure.

The benefits under the Aussie Pump warranty are in addition to other rights under Australian Consumer Law.

## STAY SAFE

**CAUTION**

### Safety Clothing

All persons operating the unit must wear protective clothing such as safety goggles, face shields, gloves, overalls or raincoat, steel cap boots and ear protection equipment as appropriate. Refer to page 3.

### Engine Hazards

Engines emit toxic poisonous carbon monoxide gas which is a colourless, odourless gas. Do not run the jetter in an enclosed area.

Petrol is extremely volatile and explosive under certain conditions. Please note the following:

- Turn off engine and allow to cool before refuelling
- Refuelling of the unit must be done in a careful manner. Do not overfill the fuel tank. Use suitable equipment for refuelling (suitable containers and funnels). Once the unit is refuelled, please ensure that the fuel tank lid is closed properly and securely.

Parts of the engine will get hot when it is running. These hot surfaces can cause burns and fire. Keep body parts away from hot areas and beware that these parts will take time to cool down. Refer page 3.

### Jetter Warning

Before starting up your Aussie Cobra drain cleaning jetter, ensure that your high pressure jetting hose has been placed in the sewer line (minimum 2 metre). This must be done before starting and engaging pressure to hose reels. If this is not followed, severe injury or death may occur.

The sewer hose has been marked at 1m, 2m and 3m from end of the hose. This ensures that the operator is aware that he is getting near to the end of his sewer hose as it is being removed from the drain or sewer line. Before removing the last two metres of sewer hose from the sewer line or drain pipe, water pressure to the nozzle **must** be shut off. Severe injury or death may occur if this procedure is not followed. Refer page 3.

### Wash Down Operation

Whilst using your wash down high pressure pump with gun and lance, please ensure that the gun and nozzle are not pointed to any persons or animal whilst in operation. Severe injury or death may result if this procedure is not followed. Refer page 3.

### Bacteria Warning

Sewer lines and drainpipes can carry bacteria and other dangerous micro-organisms which may be infectious. These may cause severe illness or death if exposed to person's mouth, nose, ears, eyes, hands or open cuts and abrasions. To protect the operator against these infectious micro-organisms or bacteria, it is imperative that arms, hands and other areas of the body must be washed after working with sewer lines with hot soapy water. Refer page 3.

**Do not smoke or eat** while using the jetter as this may lead to the transfer of dangerous micro-organisms into the body.



## SAFETY PRECAUTIONS

## CAUTION

Everyone who uses a high pressure jetter must be competent to do so.

1. Never direct the spray jet at any person or animal.
2. Never direct spray jet at any surface that may contain asbestos.
3. Do not operate the jetter with the hose end outside of the drain. The hose can whip out of control and cause injury. Skin can be penetrated by high pressure water jets.
4. Never hold a finger over the high pressure nozzle.
5. Never direct the spray jet at the machine itself or any electrical equipment.
6. After use release the pressure in the high pressure hose by operating the pistol trigger.
7. When not in use always switch off the engine and disconnect from water supply.
8. Certain engine components become very hot when in use, e.g. exhaust muffler and cylinder head. Switch off the engine and **ALLOW TO COOL** before touching.
9. Do not attempt any mechanical repair. If you have a problem with your machine contact your local dealer or Aussie Pumps service division, phone 02 8865 3500.
10. Never supply any liquid other than clean water to the water inlet.
11. Never pull the high pressure hose if it has formed kinks or nooses. Never pull the hose over sharp objects and do not allow the hose to be driven over. A damaged hose must be professionally repaired or replaced.
12. Use in a well-ventilated area.
13. Ensure unit is operated on a level surface; wheels should be chocked before use.
14. Do not attempt to disconnect any hose or coupling with pressure still in the hose.
15. Do not operate the machine whilst standing on ladders; use a platform tower or scaffolding.
16. Use safety goggles when using the machine, particularly with the sand blasting attachment, or any application where loose particles of stone or grit, etc, may be blown around by the high pressure spray.



\*\*\*\* IMPORTANT \*\*\*\*

COMPLETE A RISK ASSESSMENT OF THE SITE AND JOB BEFORE YOU START.

A risk assessment form has been included at the beginning of this manual for your convenience.

17. Stay alert and pay attention to what you are doing and the machine you are operating. Do not use jetter while you are tired or under the influence of drugs, alcohol or medication.

## Work Area Safety ... minimise hazards

Keep work area clean and well lit.

Set up the jetter and work area in such a way as to reduce the risk of injury from high pressure water, chemical burns, infections, carbon monoxide and other causes.

Mark off the area with barriers if necessary to keep bystanders, passing traffic and non-essential personal away.

Check for flammable or poisonous liquids, vapours and dust that may ignite. Do not operate jetter until the area has been made safe.

Check the condition of the drains before starting to jet. Drains that are in good condition will not be damaged by the jetting process. Poorly maintained or constructed drains may result in jetting being less effective and could lead to further damage to the drain.

### Aussie Pro-Operator

- Overalls
- Aprons
- Jackets
- Trousers
- Gloves



## Specifications

	Mini Cobra	Cobra	King Cobra (Honda)	King Cobra (Vanguard)	King Cobra (Kohler)	Python (pump motor group)
<b>Drain size</b>	Up to 6"	Up to 8"	Up to 8"	Up to 8"	Up to 8"	Up to 8"
<b>Max water delivery</b>	13 lpm	20 lpm	20 lpm	25 lpm	25 lpm	31 lpm
<b>Max Output pressure</b>	4,300 psi	4,300 psi	5,000 psi	5,000 psi	5,000 psi	4,300 psi
<b>Engine model</b>	Honda 13HP GX390	Honda 21HP GX630	Honda 28HP GX690	Vanguard 27HP	Kohler 23HP	Vanguard 35HP or Kohler diesel
<b>Fuel</b>	Petrol	Petrol	Petrol	Petrol	Diesel	Diesel
<b>Cooling</b>	Air	Air	Air	Air	Air	Air
<b>Starting system</b>	Recoil	Electric start	Electric start	Electric start	Electric start	Electric start
<b>Battery</b>	-	Dry cell	Dry cell	Dry cell	Dry cell	Dry cell
<b>Pump</b>	Bertolini TTL1330	Bertolini TTL2030	Bertolini RAL2035	Bertolini RAL2535	Bertolini RAL2535	Bertolini RAS4482
<b>RPM</b>	1450	1450	1450	1450	1450	1450
<b>Hose supplied</b>	30m x 1/4"	60m x 1/4"	60m x 1/4"	60m x 1/4"	60m x 1/4"	Optional
<b>Drain Cleaning Nozzles Supplied</b>	Penetrator, Negotiator & Root Mulcher	Aussie Jetters Nozzle Box	Aussie Jetters Nozzle Box	Aussie Jetters Nozzle Box	Aussie Jetters Nozzle Box	Optional

## Accessory Identification

### Jetter Accessories

The Aussie Jetter is equipped with the following jetting accessories:

- 1 x Aussie steel hose reel (option with Python)
- 60 metres of 5,000 psi rated 1/4" ID R8 sewer cleaning hose with quick fit snap on connection on outlet (30m on Mini Cobra).
- Aussie Jetter Nozzle box (not supplied as standard with Mini Cobra or Python);
  - 1 x Penetrator nozzle with 3 rear jets and 1 forward jet,
  - 1 x Negotiator nozzle with 6 rear jets and 1 forward jet.
  - 1 x Aussie Root Mulcher rear turbine root cutter.
  - 1 x Compressor nozzle
  - 1 x spare snap on coupler
  - 1 x tip cleaner & allen key for nozzle disassembly



1 x heavy duty wash down gun with 400mm stainless steel lance & high pressure nozzle.

**All nozzles suited for the sewer hose come with quick fit snap on tail for connection of hose.**

**Please check that all accessories are supplied carefully as claims will not be accepted seven (7) days after purchase date.**

### Optional Accessories

- a) Extra hose lengths in various widths, 1/4", 3/16" & 1/8".
- b) Extra nozzles (see Nozzle Selection page 13).
- c) Aussie Viper Mini reel, mobile hose reel fitted with either 1/4" high pressure sewer hose or 3/16" lightweight sewer hose.



- d) Super worm hose, 1/8" super flexible hose, ideal for small drains & tight bends. Complete with compressor nozzle quick fit tail.

## Assembly & Preparation for Use

### Pump / Gearbox / Engine

1. Check the oil in the pump, gearbox & engine

Note there are separate oil reservoirs for pump and gearbox.

With the machine on a level surface, the pump oil level should cover the red spot in the oil level sight glass on the side of the pump.

If necessary, top up with **SAE 75W-90** oil (non-foaming type). Do not mix different grades of oil as this may affect the machine's performance. If alternative oil is used, first empty out oil by unscrewing drain plug in bottom of machine.

2. Ensure breather plug is fitted to pump (red).
3. Note that the gearbox has a separate oil reservoir. Gearbox oil is **SAE 80W90** gear oil.
4. Check engine oil level. Refer to engine manufacturer's separate handbook.

Pump breather



Gearbox sight glass

Pump sight glass

\*\*\*\* IMPORTANT \*\*\*\*

Oil loses its lubricity over time. Change pump & gearbox oil every 3 months during regular service

**FAILURE TO CARRY OUT REGULAR MAINTENANCE  
VOIDS WARRANTY!**

## Start Up & Operation

### Water Supply Hose

- Use a good quality garden hose of ¾" (25mm) diameter minimum (not supplied).
- Ensure the supply hose has been flushed to remove any insects, reptiles or obstructions before attaching to the jetter.



- Fasten one end of the hose to the inlet hose connector fitted to inlet on break tank and the other to the tap.
- The brake tank is fitted with a low water cut out. The engine will not run if the water level drops below this point.
- **NOTE:** Mini Cobra is not fitted with a brake tank. An appropriate back flow prevention device should be used to comply with all local water authority regulations.
- To prevent the ingress of foreign bodies into the pump the jetter is fitted an Aussie Pump Saver Filter. Check filter regularly and rinse element. (See Pressure Cleaner Daily Check List on page 20.)

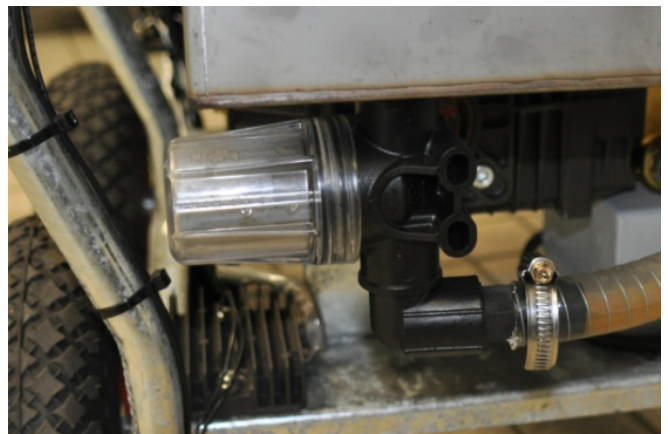



Operation as a Drain Cleaning Jetter



The ball valve on the jetter acts like the trigger on a high pressure spray gun.

- Turn on water supply. Note: Tap should be fully on.
- Ensure break tank is full and float valve has shut off. (NOTE Mini Cobra is not fitted with a break tank).

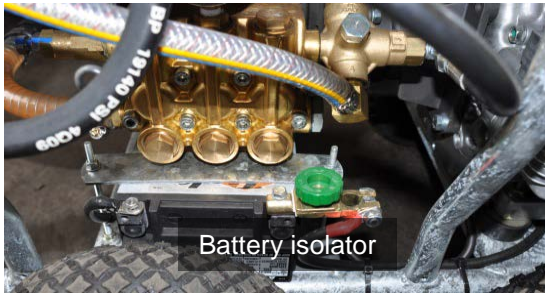

- Connect battery isolator.
- Ensure breather vent in fuel tank cap is open.



- Attach selected drain cleaning nozzle to end of sewer hose and ensure it is **fully snapped into position**.



- Place at least 2 metres of hose down the drain, use hose markings as a guide.

- Start the engine. Ensure fuel tap is open, choke is fully open and turn the key or pull the starter rope to start engine. (Refer to engine manual for more details). Adjust throttle speed as required.
- Check there are no leaks in the line connections. All leaks must be fixed before using the jetter.
- Turn on ball valve to activate high pressure jet to nozzle.
- Ease the hose down the drain. Twist the hose to aid the nozzle in negotiating bends and turns. The nozzle will create a gentle pulling action on the hose. If it becomes stuck a sharp tug will usually free it.

For more jetting tips check out page 12.

**Changing Nozzles**

- Turn off the ball valve before removing the hose out of the drain.
- Change over the nozzle as required, ensuring the nozzle is fully snapped into position.

**WARNING:** When removing hose from drain you must turn off the ball valve before or as the 2 metre mark on the hose appears. The hose has been marked for your safety and these marks must be renewed as required.

\*\*\*\* IMPORTANT \*\*\*\*

**WARNING ... DO NOT RUN EXCESSIVE BY-PASS.** Switch machine off within two minutes of ceasing operation as excessive by-pass can cause heat build-up in pump and subsequent damage.

*EXCESSIVE BY-PASS RUNNING VOIDS WARRANTY!*

**Turning off the Jetter**

- Turn off the ball valve and pull the hose out of the drain.
- De-throttle the engine and turn off.
- Release the pressure still in the hose by opening and closing the ball valve.
- Ensure the engine key is turned to the off position and the fuel tap is off.
- Isolate the battery.
- Disconnect the supply hose.

Operation as a High Pressure Washer

- Turn on water supply. Note: Tap should be full on.
- Ensure break tank is full and float valve has shut off.
- Fit the gun/lance assembly to the end of the sewer hose
- Open the ball valve.

- Start the engine. Ensure fuel tap is open, choke is fully open and turnkey or pull starter rope to start engine. (Refer to engine manual for more details). Adjust throttle speed as required.
- Check there are no leaks in the line connections. All leaks must be fixed before using the jetter.
- When using gun and lance pressure begins when the gun trigger is squeezed.

### Turning off the Pressure Washer

- De-throttle the engine and turn off.
- Release the pressure still in the hose by opening and closing the gun trigger.
- Ensure the engine key is turned to the off position and the fuel tap is off.
- Isolate the battery.
- Disconnect the supply hose.

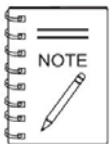

**NOTE:** Aussie Drain Cleaning jetters are fitted with an Absorbed Glass Mat dry cell battery. It may be necessary to run the jetter for at least 20 mins to recharge the battery from time to time. If the battery is flat it **must** be recharged using a **Trickle**

**Charge battery charger.** Contact a battery specialist for further assistance.

## ASP System ... Aussie Safety Protection System

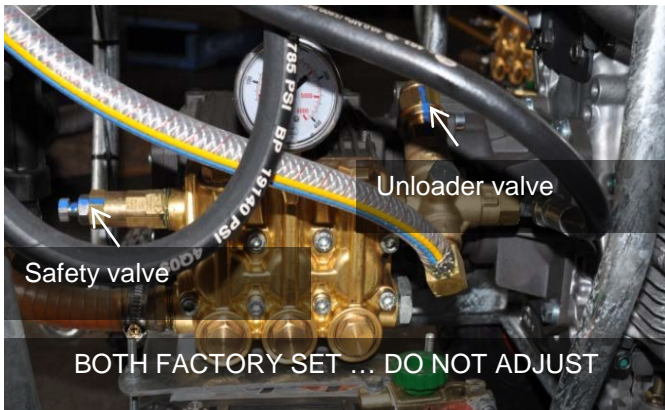

**DO NOT** allow machine to run on by-pass for more than 2 minutes.

**AUSSIE SAFETY VALVE:** This device “blows off” excess pressure if unloader has been tampered with, thus protecting the pump.

Do not tamper with pre-set unloader and safety valve. **(This will void your warranty.)**

\*\*\*\* IMPORTANT \*\*\*\*

**WARNING ... ALTERING OF HIGH PRESSURE PUMPING SYSTEM MAY RESULT IN SEVERE INJURY OR DEATH.**

Warranty will be void if any high pressure equipment has been altered by unauthorised persons. Over-speeding or over-pressurizing of pumping system can be very dangerous and severely reduce the life of your Aussie Cobra Drain Cleaning Jetter and may result in injury or death.

## High Pressure Piston Pumps & Plumbing

Your high pressure Bertolini pumping system is the heart of your drain cleaning jetter. The Pump has been specially designed to be used with cold water (max 74°C) for pipe water jetting and high pressure wash down applications. Your high pressure Bertolini piston pump is designed to move a certain amount of water per revolution by its three solid ceramic pistons.

High pressure is created once the pump outlet is restricted with a nozzle. All high pressure outlet connections, hosing and equipment is rated over and above the maximum operating pressures of the pump.

Do not adjust any valves on your pump; tampering will void warranty. For any malfunction of the high pressure pumping system, please contact Australian Pump Industries or authorised Aussie Pump Service Agent.

Because of safety/danger hazards with high pressure systems, only use approved genuine Aussie high pressure hoses and components when replacing or repairing your Aussie Cobra drain cleaning jetter. For guidance on this, please contact Australian Pump Industries or the Distributor you purchased the unit from.

### IMPORTANT ... Nozzle Wear

Once drain cleaning nozzles or wash down nozzles have worn, pressure loss will occur. Replacement of nozzles is necessary to maintain constant and maximum efficiency of your Aussie Cobra drain cleaning jetter.

**Using worn nozzles will reduce unloader valve service life.**

## Personal Protective Equipment ... STAY SAFE



Appropriate personal protective equipment should be worn where:

- hazards cannot be otherwise prevented or suitably controlled, e.g. by engineering or administration controls, total enclosure or substitution; and/or
- complete protection is essential, e.g. in some occupational environments with uncertain levels of hazards.

The provision and use of personal protective equipment does not reduce or replace the need for proper Occupational Health and Safety prevention measures, such as engineering or administrative controls to be undertaken. Recommendations of such preventative measures should always be fully explored before considering issue of personal protective equipment. Where personal protective equipment is issued, instruction and training should be provided regarding its correct use and maintenance.

- **Head Protection.**  
Where appropriate suitable head protection complying with AS/NZS 1808 should be worn.

- **Eye Protection.**  
Eye protection complying with AS/NZS 1337 (adequate for the purpose and of adequate fit on the person) should be worn at all times when in the vicinity of water blasting operations. Where liquid is liable to cause eye damage, full visor and goggles are recommended.
- **Body Protection.**  
All persons should wear suitable waterproof clothing complying with AS 3765.1 or AS 3765.2 as appropriate, having regard to the type of work being undertaken. Liquid or chemical-resistant suits should be worn where there is an assessed risk to health or of injury that can be prevented by such equipment.
- **Hand Protection.**  
Adequate hand protection complying with the recommendation/s of AS/NZS 2161.2, AS/NZS 2161.3 or AS/NZS 2161.5 should be worn when there is an assessed risk of injury that can be prevented by such equipment.
- **Foot Protection.**  
All persons should wear appropriate occupational protective footwear complying with AS/NZS 2210.2. A metatarsal and lower leg guard should be used by water blasting operators where it is assessed that the risk of foot injury could be prevented by such equipment. AS/NZS 2210.1 provides guidance for the selection of footwear.
- **Hearing Protection.**  
Suitable hearing protection complying with AS 1270 should be worn at all times when the noise levels exceed limits set by regulatory authorities.

### **Comfort, function & Safety ... at an affordable price**

Aussie Pumps supply a full range of personal safety protection gear rated to 500 BAR (7,300 psi)... call for details or check online ... [www.aussiepumps.com.au](http://www.aussiepumps.com.au)





## Operating Tips

These are some of the tips and techniques that have been tried and tested over the years to make jetting easier.

- Select your hose diameter according to the size of drain you are cleaning.

Jetter Hose Selection	
Pipe size	Sewer hose size
1"- 4"	1/8"
2"- 6"	1/4"
5"- 10"	3/8"

- Always protect your jet hose to prevent damage from sharp edges and rough surfaces. Use a short section of Ag pipe or conduit at the entry to the drain and feed the sewer hose down inside it. More damage is done to a hose on the entry and exit point of the drain than anywhere else.



- If there is a u bend, push the Ag hose down as far as the bend to protect the sewer hose from abrasion on the inside corner of the bend.
- If the drain entry is in a manhole or storm grate use PVC pipe or Ag pipe to create a guide for the jetter's sewer hose.
- Start your jetting with a long nozzle like the Predator or for smaller drains the Compressor.
- For really tight bends remove the quick coupler from the hose and cowl from the nozzle and connect the head directly to the hose.
- Twist your jet hose to help get it around tight bends and traps.
- Once you have broken through the blockage change to a Root Ranger to clear tree roots from the sides of the drain. When using the Root Ranger Turbine, the hose must be twisted to thoroughly clear the root choke from all sides of the pipe.

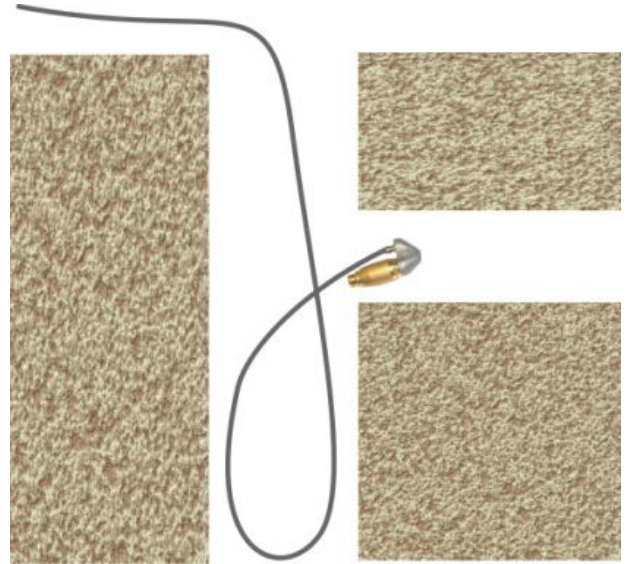

- Prevent the Root Ranger turbine from entering side channels by pushing straight through the junction as quickly as possible. Pushing the hose straight without twisting it, will help to keep the turbine on a straight path.
- If your hose becomes jammed, try pulling the hose hard, and then letting it go quickly so it can snap back and loosen itself. Also, try turning the jet off then pull on the hose, then turn jet back on again.
- When jetting down a shaft in an attempt to get your hose up a junction, try bending the hose back on itself so the nozzle is pointing back towards you. Push the hose down the shaft until the nozzle lines up with the junction. When nozzle is in the junction, turn the jet on slowly until nozzle pulls itself up the pipe. If the nozzle does not go up the junction, it will come back up the shaft, so take extreme caution when using this method to access junction.

As good as the Aussie Turbo Root Mulcher is it likes to get stuck wherever possible.

- Try running the RR straight to the blockage without twisting the hose.
- Leave the hose twist for when you are actually cutting the roots or retrieving the hose from the blockage. This will keep it from heading up any branch drains, toilet pans and PVC capped inspection openings!
- For drains larger than 6" add an extension to the Root Ranger to prevent it from becoming wedged.

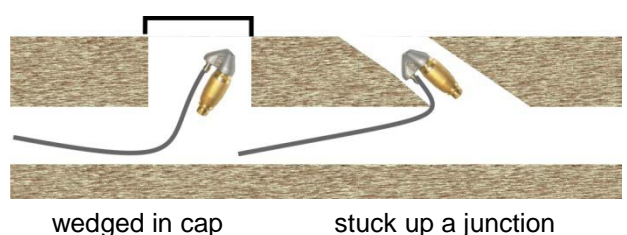



## Nozzle Selection

There are 3 main types of penetrating nozzles; the Predator, the Negotiator, and the Compressor. These 3 nozzles come in different configuration options – 3 rear 1 forward, 6 rear, 1 forward, and 6 rear only. The beaver has 6 rear jets and 2 forward jets.

**The Predator** is a good starting choice for general drain cleaning. It has a long pointed nose for penetrating deep into a choke and blasting out the debris. (AD P3R1FC)

**The Negotiator** has been designed shorter to get around tight bends and traps. It is a good multi-purpose nozzle for any drain cleaning application. (AD N6R1FC)

**The Compressor** is smaller again, and assists with smaller blockages. A new extension can also be purchased for the Compressor nozzle. (AD C6R1FC)

**The Beaver** has 2 forward firing jets, with 6 reverse thrusting jets. The 2 front jets bore deep into the choke. Ideal for dry chokes. (AD BV6R2FC)

**The Root Rat** is extremely popular. It features 1 front jet with 6 rear jets, 3 behind the tip of the nozzle at 45° and 3 at the rear of the nozzle at 30°, enabling it to quickly penetrate the choke. (AD RR6R1FC)



**The Bullet** is a small, but powerful nozzle used when all else fails. Although it is very effective, it should only be used on difficult chokes. It is so small it has a habit of leaving the drain. (AD B6R1FC)

**The Root Ranger** is used to clear what the Penetrator nozzles leave behind. It has 1 rear thrust port and an optional front jet. This nozzle will clear just about anything from the drain and is the primary root cutter used by plumbers worldwide. (AD RR8TCF)

**6" Root Ranger** is used with larger jettors like the Python. (AD LRR8TC)



**Using worn nozzles will reduce unloader valve service life.**

**NEW NOZZLES MAKE YOU FOB EASIER ... ASK ABOUT OUR LATEST DRAIN CLEANING NOZZLES.**

## ACCESS HARD TO REACH JOBS WITH THE AUSSIE VIPER MINI REEL ..... remote jetter control



- Connect the jetter sewer hose to the Viper Mini reel.
- Use the ball valve on the reel to control the pressure to the sewer hose.
- Extends your reach an extra 30m.
- Essential kit if your jetter is ute mounted



## Operator's Hand Signals

*This section provides a set of hand signals for communication when carrying out water jetting operations.*

### ■ Pressurise System

Thumb pointing upwards, the rest of the hand closed. From the shoulder height the arm moves up and down.



### ■ Depressure System.

Form a fist. Move the arm back and forth at shoulder height.

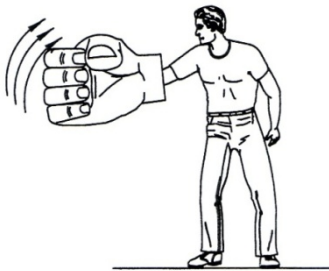

### ■ Raise Pressure.

First finger pointing up, the rest of the hand closed. The hand is moved in a circular motion.



### ■ Lower Pressure.

First finger pointing down, the rest of the hand closed. The hand is moved in a circular motion.



## Accident Reporting

### ■ Reporting.

All accidents or injuries, whether resulting in "lost time" or "no lost time" injuries, should be recorded in accordance with the recommendations of AS 1885.1.

Incidents that result in "near misses" should also be recorded as a means of providing a record of significant incidents that have the potential to result in serious injury at the workplace, so appropriate measures can be implemented to minimise or eliminate these potential hazards.

### ■ Personal Injuries.

In the event that a person is injured by the impact of a water jet, the injury caused may appear insignificant and give little indication of the extent of the injury beneath the skin and the damage to deeper tissues. Although only a small hole may be present, quantities of water may have penetrated the skin and entered the flesh and organs causing serious injury.

### ■ Medical Recommendation.

If an accident occurs where pressurised water penetrates or appears to have penetrated the skin, medical assistance should be sought immediately.

### ■ Immediate First Aid.

Where medical examination is not immediately possible (e.g. in remote situations), appropriate basic first aid measures should be applied and the patient observed closely until medical treatment is available.

### ■ Medical Alert Card.

All operators engaged in commercial and industrial water blasting operations should carry out an immediately accessible, waterproof medical alert card. This card should:

- outline the possible nature of injuries and post-accident infections that can be caused by high pressure water blasting;
- provide details of immediate first-aid treatment until medical treatment can be arranged; and
- provide the name or names of medicos (and contact phone numbers) who should be contacted for expert medical advice for the treatment of high pressure water blasting injuries.

In addition, the card may also:

- identify the worker; and
- outline medical information about the worker; e.g. blood type, allergies and conditions, such as asthma.



## Maintenance, Service and Spares

Your Aussie Eco-Clean drain cleaning jetter has been designed to give you long and trouble-free service.

If however, you have a problem which cannot be resolved by referring to the Troubleshooting Guide below, or if you require spare parts or servicing, contact your local dealer (check the website for list; [www.aussiepump.com.au](http://www.aussiepump.com.au)) or call **Aussie Pumps** on **(02) 8865 3500**.

## Troubleshooting Guide

FAULT	CAUSE	REMEDY
Pump running normally but pressure low on installation	Pump sucking air Valves sticking, dirt in valves Unloader valve seat faulty Nozzle incorrectly sized Worn piston packing	Check water supply and possibility of air ingress Check and clean or replace if necessary Check and replace Check and replace Check and replace
Fluctuating pressure	Valves worn Valves blocked Pump sucking air  Worn piston packing	Check and replace Check and clean out if necessary Check water supply and air ingress at joints in suction line Check and replace
Pressure low after period of normal use	Nozzle worn Suction or delivery valves worn Suction or delivery valves blocked Unloader valve seat worn Worn piston packing	Check and replace Check and replace Check and clean if necessary Check and replace if necessary Check and replace if necessary
Pump noisy	Air in suction  Broken or weak suction or delivery valve spring Foreign matter in valves Worn bearings Excessive temperature of liquid	Check water supply and connections on suction line Check and replace if necessary  Check and clean if necessary Check and replace if necessary Reduce temperature
Presence of water in oil	Oil seal worn High humidity in air Piston packing worn	Check and replace Check and change oil twice as often Check and replace if necessary
Water dripping from under pump	Piston packing worn Plunger retainer worn	Check and replace Check and replace
Oil dripping	Oil seal worn	Check and replace if necessary
By pass valve switches repeatedly when gun is off	Leaking gun and/or pressure pipe Leaky sleeve Worn out kick-back valve body  Leaky seals	Renew gun, seal pressure pipe Renew sleeve Check and renew as necessary kick-back valve plate and seat Renew seals
Leaky piston rod	Defective o-ring/support ring	Renew piston rod seals and examine surfaces in guide case
Leaky by-pass at nominal pressure	Nozzle too small, too much water Worn out by-pass valve	Install larger nozzle Examine and renew as necessary
Pressure gauge shows high pressure fluctuations when shutting off gun	Valve set too high above operating pressure Dirty valve	Adjust the unloader at the operating pressure  Clean valve (removing lime deposits, etc) Grease parts before installing
Engine will not start	Out of petrol Engine defect Battery flat	Fill tank with petrol Return to engine service agent Use a trickle charge recharging unit only or contact a battery specialist

\*\*\*\* WARNING \*\*\*\*  
**CHECK OIL LEVEL IN PUMP REGULARLY. DO NOT OVERFILL.**



## Pump Kits

PUMP PARTS RAL 2035H (King Cobra Honda)  
RAL 2535H (King Cobra Vanguard & Kohler)

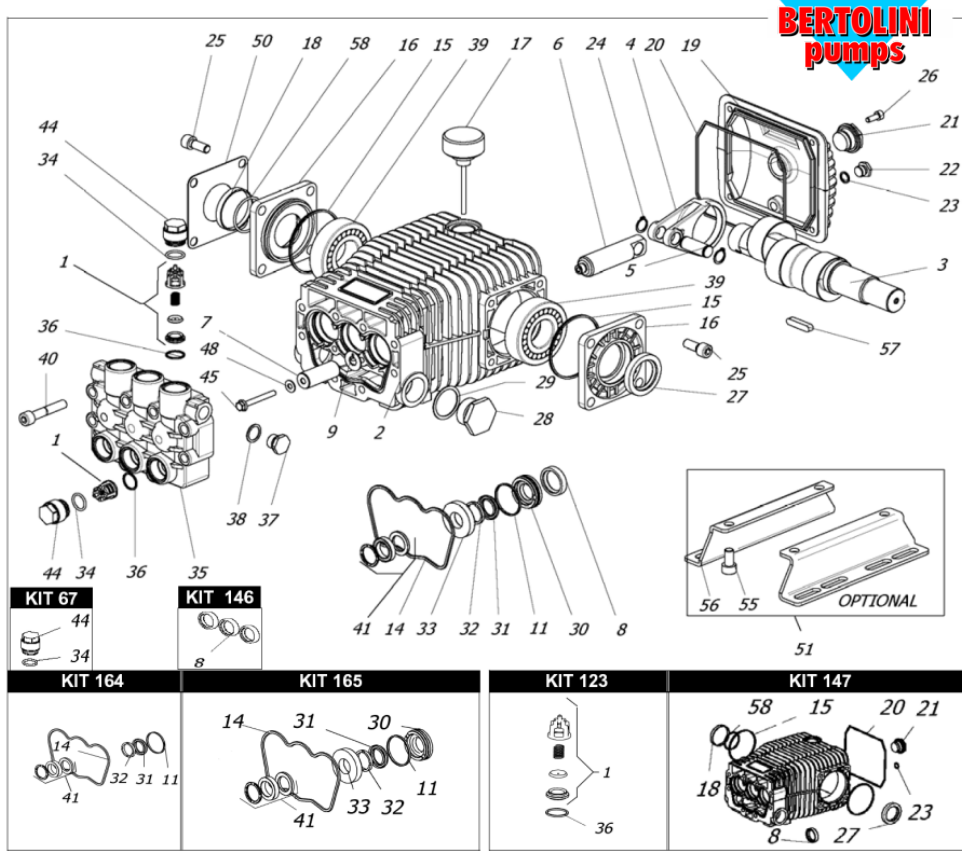

Kit No.	Part No.	Description	Pieces
123	BKIT123	VALVE KIT	12
164	BKIT164	SEAL KIT MINOR	19
165	BKIT165	SEAL KIT MAJOR	25
146	BKIT146	OIL SEAL KIT	3
67	BKIT67	CAP KIT	12
147	BKIT147	O-RING & GLASS KIT	11

PUMP PARTS RAS 4482 (Python)

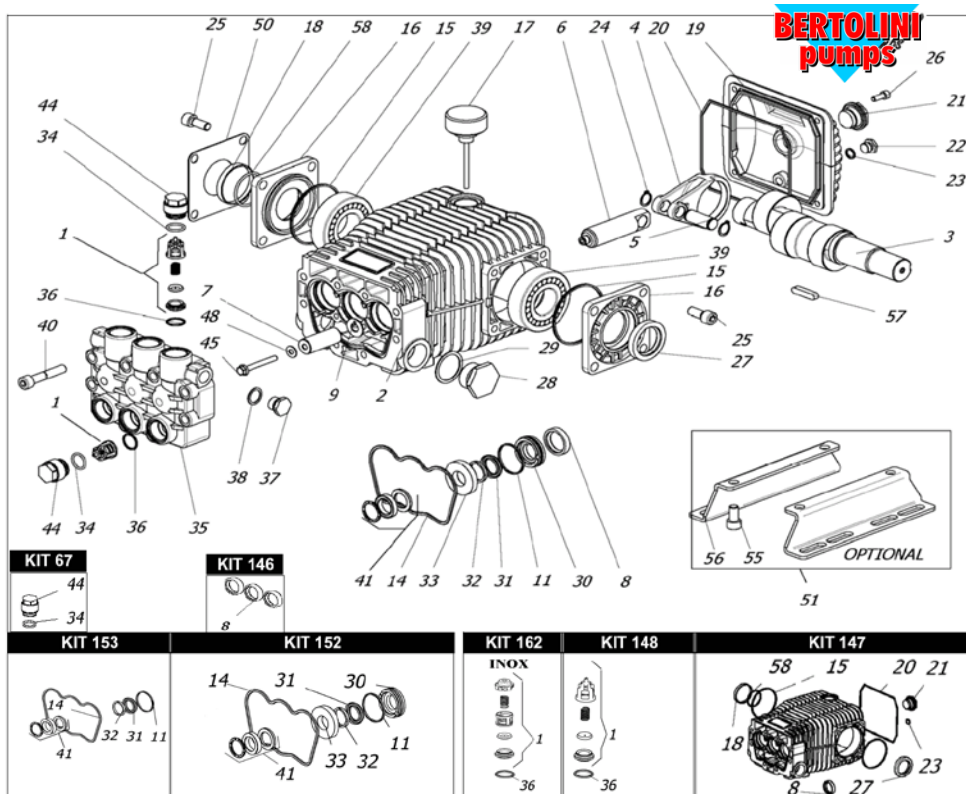

Kit No.	Part No.	Description	Pieces
148	BKIT148	VALVE KIT	12
153	BKIT153	SEAL KIT MINOR	19
152	BKIT152	SEAL KIT MAJOR	25
146	BKIT146	OIL SEAL KIT	3
67	BKIT67	CAP KIT	12
147	BKIT147	O-RING & GLASS KIT	11

Order the right part first time ... specify the pump model number when ordering parts.

Full parts breakdowns available online ...

[www.aussiepumps.com.au](http://www.aussiepumps.com.au)

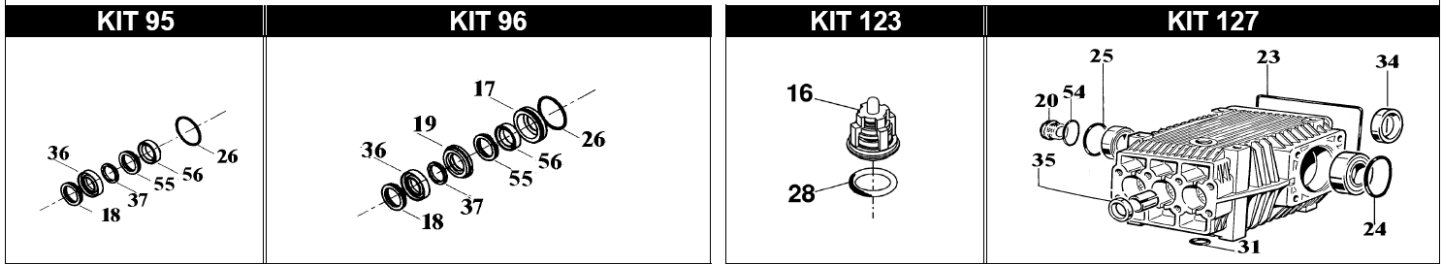
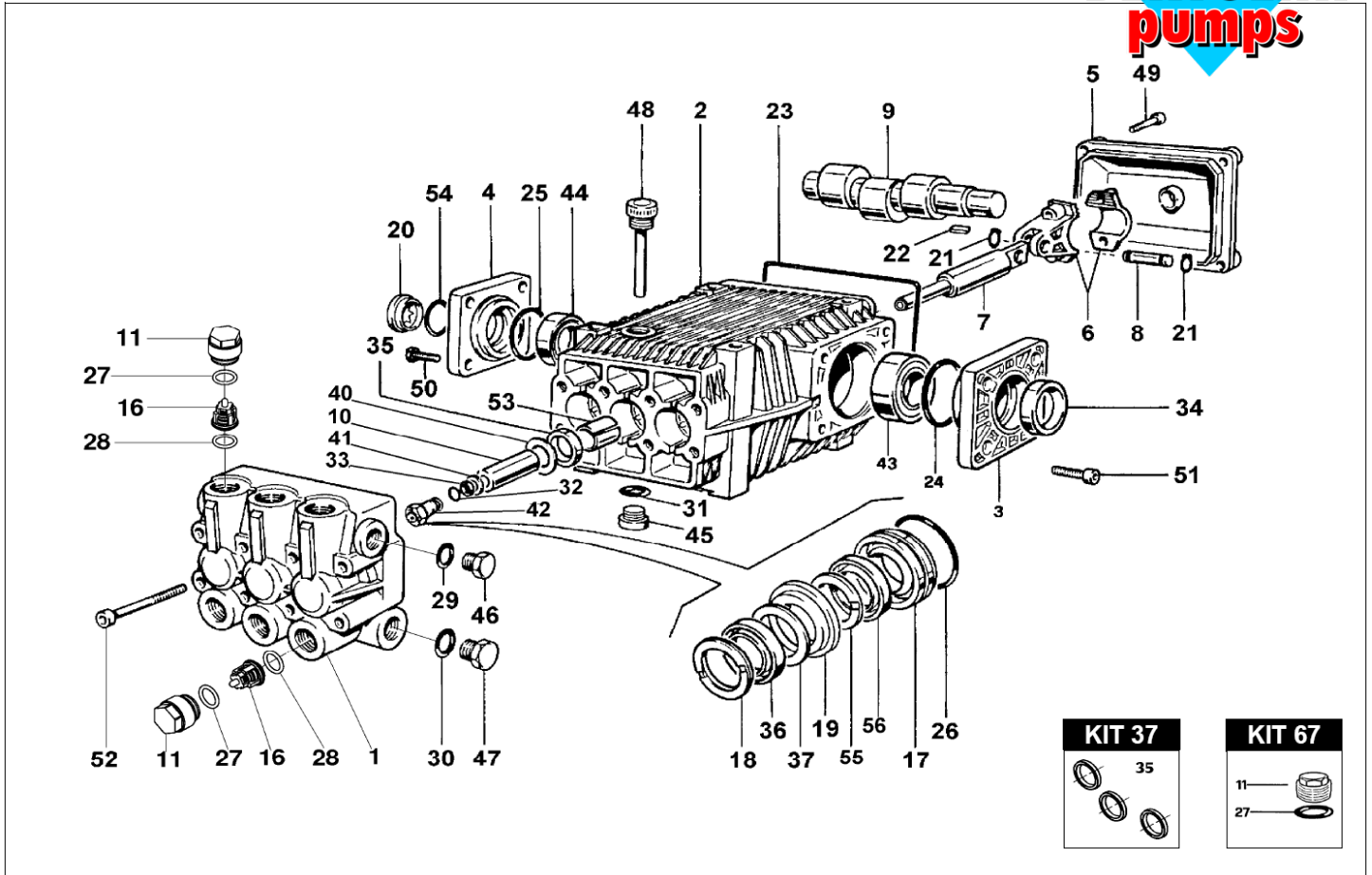

Kit No.	Part No.	Description	Pieces
127	BKIT127	Full Oil seal & Sight Glass kit	10
123	BKIT123	Valve Kit	12
95	BKIT95	Seal Kit Minor	18
96	BKIT96	Seal Kit Major	24
37	BKIT37	Oil Seal Kit	3
67	BKIT67	Valve cap kit	12

Order the right part first time ...  
specify the pump model number when ordering parts.

Full parts breakdowns available online ... [www.aussiepumps.com.au](http://www.aussiepumps.com.au)

Aussie Blasters Service Fundamentals covers servicing of high pressure piston pumps in detail.

Download this useful service guide from the Aussie website or call for your FREE copy.

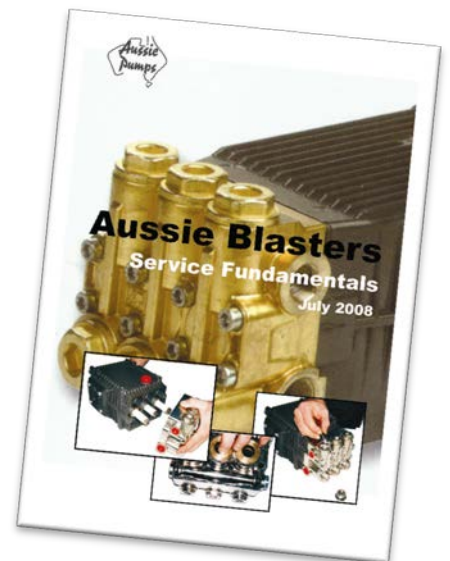

## Replacement Parts

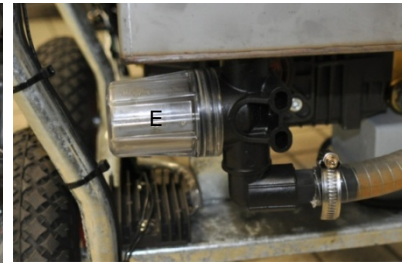
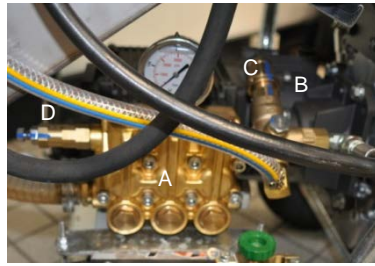
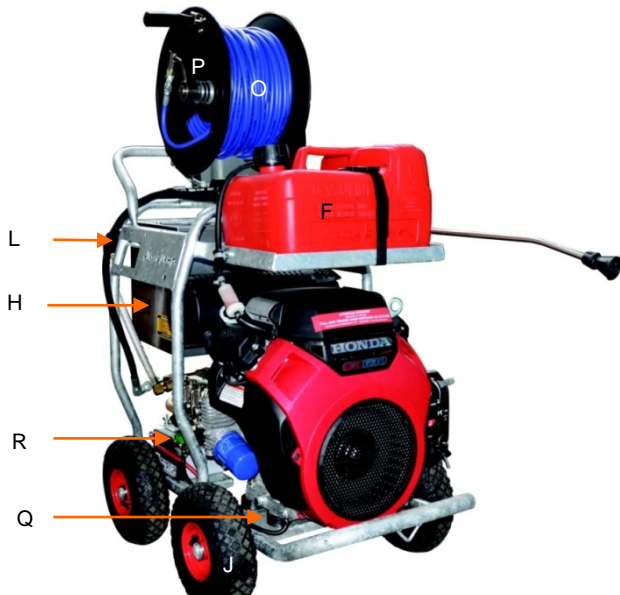

Position	Part No	Description	Mini Cobra	Cobra	King Cobra	Python
<b>Pump</b>						
A	BTTL1330	BERTOLINI PUMP (4,300 PSI, 13 LPM)	x			
	BTTL2030	BERTOLINI PUMP (4,300 PSI, 20 LPM)		x		
	BRAL2035	BERTOLINI PUMP (5,000 PSI, 20 LPM)				
	BRAL2535	BERTOLINI PUMP (5,000 PSI, 25 LPM)			x (Honda)	
	BRAS4482	BERTOLINI PUMP (4,300 PSI, 31 LPM)			x (Vanguard, Kohler)	
<b>Gearboxes</b>						
B	B318870973	GEARBOX (1" PTO)	x	x		
	B318880973	GEARBOX (1 1/8" PTO)			x	x
<b>Unloader</b>						
C	BVB350	UNLOADER VALVE (5100 PSI)	x	x	x	
	BVB80/280	UNLOADER VALVE (4,000 PSI)				x
<b>Safety Valves</b>						
D	MPA60156000	4000 PSI SAFETY VALVE	x	x		
	MPA60058000	5650 PSI BVS350 SAFETY VALVE			x	x
<b>Thermal Dump</b>						
not shown	MPA60063070	THERMAL DUMP	x			
<b>Pump Filter</b>						
E	AYSTRAINER3/4	BRASS Y STRAINER 3/4"	x			
	M8105038	3/4" F LINE STRAINER 80 MESH		x	x	
	JP15-1RLA60P-1V	5" CARTRIDGE FILTER 60 MICRON				x
<b>Fuel Tank</b>						
F	AFUELTANKCOBRA	12 LITRE FUEL TANK		x	x	
<b>Gauge</b>						
Not shown	AGCDR0102	6000 PSI GAUGE	x	x	x	x
<b>Water Tanks</b>						
H	ATANKSSCOBRA	S/STEEL WATER TANK		x	x	
	MTM00010300	FLOAT VALVE		x	x	
<b>Ball Valves &amp; Handles</b>						
Not shown	MTM00089501	BALL VALVE 1/4"		x	x	
	MTM00089502	BALL VALVE 3/8"	x			
<b>Wheel</b>						
J	A400016	10" SCUD WHEEL	x			
	AWHEELCOBRA	10" WHEEL WITH PNEUMATIC TYRE		x	x	
<b>Nozzles (in lance)</b>						
K	C915 ___ M	HP NOZZLE (15° ANGLE, TIP SIZE ... refer to table)	030	055	045	070
<b>Whip Hose</b>						
L	AR206S166MPX1.6	1.6M WHIP HOSE		x	x	
	AR20690C8FB40.6	0.6M WHIP HOSE	x			
<b>Lance</b>						
M	C3930.00	400M SS SINGLE LANCE	x	x	x	x
<b>Gun</b>						
N	M200917400	AL50 4,000 PSI RATED GUN WITH EXTENSION	x	x		x
	M4022123000	ML2002 5,000 PSI RATED GUN WITH EXTENSION			x	
<b>Hose</b>						
O	AHOSER8 1/4 30M	HOSE R8 1/4 30M 5000PSI	x			
	AHOSER8 1/4 60M	HOSE R8 1/4 60M 5000PSI		x	x	
<b>Hose Reels</b>						
P	AD30001	HOSE REEL 3500 PSI	x			
	ADHR50150D	HOSE REEL 5000 PSI		x	x	
<b>Engine Accessories</b>						
Q	AENGINEMOUNT300	ENGINE MOUNT (4 NEEDED)	x	x	x	x
R	ABATTERYKEN	DRY CELL BATTERY		x	x	x

## Warnings

### ❖ OVER SPEEDING

Do not operate machine at over 3200rpm (engine speed - preset).  
Over-speeding can cause serious pump damage and will void warranty.

### ❖ EXCESSIVE BY-PASS

Do not run on excessive by-pass. Switch machine off within two minutes of ceasing operation as excessive by-pass can cause heat build-up in pump and subsequent damage. Excessive by-pass running voids warranty. This does not apply to machines fitted with supply tanks.

### ❖ HIGH PRESSURE SETTING

The high pressure pump is factory set to operate at its rated pressure. **DO NOT ADJUST.** Tampering with the pressure regulator will void warranty and can be DANGEROUS.

### ❖ CHECK NOZZLES & COUPLINGS WEEKLY, clean after each use.

If pressure drops off, check nozzle for wear. Nozzles should be replaced on a regular basis (every month for machines in regular use, every three months for machines used intermittently). Using the machine with the incorrect nozzle size or worn nozzle will void warranty and can be DANGEROUS to the operator.

## Pressure Cleaner Daily Check List

1. Check pump & gearbox oil level.
2. Check engine oil level.
3. Check nozzle for wear.
4. Check all high pressure components for leaks, damage, wear or corrosion:
  - (a) Gun/Lance.
  - (b) HP hose & connections
  - (c) All fittings.
5. Check water filter and clean if necessary.
6. Check unloader & safety valve for leaks.

## Three Monthly Regular Service

All professional machines need to be thoroughly serviced every three months. The service involved should include the engine manufacturer's recommendations (see separate Engine Manual) and the following:

1. Change pump & gearbox oil.
2. Change engine oil if required (refer to engine manual for schedule).
3. Check filter for foreign debris.
4. Check unloader & safety valve for leaks.
5. Check all HP components, including the hose, for leaks, damage, wear or corrosion. Replace if necessary.
6. Replace nozzles.
7. Check gearbox to engine key for wear, if key is worn see your local Aussie Eco-Clean Service Department.

**NB. Damage generated by worn keys is not covered by warranty!**

LOOK AFTER YOUR MACHINE AND IT WILL LOOK AFTER YOU.



AUSTRALIAN PUMP INDUSTRIES

7 Gladstone Road, CASTLE HILL NSW 2154

PO Box 6164, Baulkham Hills Business Park NSW 2153

Ph: (02) 8865 3500 info@aussiepumps.com.au www.aussiepumps.com.au